

**SCHEDULE H  
PARKING REQUIREMENTS  
TABLE OF CONTENTS**

<b>SECTION 1.0</b>	<b>PURPOSE</b> .....	<b>1</b>
<b>SECTION 2.0</b>	<b>APPLICABILITY</b> .....	<b>1</b>
<b>SECTION 3.0</b>	<b>UNSPECIFIED USES</b> .....	<b>1</b>
<b>SECTION 4.0</b>	<b>JOINT USE OF PARKING FACILITIES</b> .....	<b>1</b>
A.	Shared Parking.....	1
B.	Covenant Required.....	1
<b>SECTION 5.0</b>	<b>REDUCTIONS AND INCREASES IN REQUIRED NUMBER OF PARKING SPACES</b> .....	<b>2</b>
<b>SECTION 6.0</b>	<b>BICYCLE PARKING REQUIRED</b> .....	<b>2</b>
A.	Purpose.....	2
B.	Applicability.....	2
C.	Exemptions.....	2
D.	Bicycle Parking Spaces Required.....	3
E.	Location of Short-Term Bicycle Parking Facilities.....	3
F.	Design of Parking Facilities.....	3
G.	Specifications for the "Inverted U" Type Bicycle Rack.....	4
H.	Long Term Bicycle Parking Facilities.....	5
<b>SECTION 7.0</b>	<b>OFF-STREET PARKING REQUIREMENTS</b> .....	<b>5</b>
A.	Number of Automobile Parking Spaces.....	5
B.	Parking in the Special Commercial Zoning District (SC-3).....	8
C.	Maximum Number of Parking Spaces.....	9
D.	Parking of Company Vehicles.....	9
E.	Off-Street Parking Structures.....	9
F.	Fee In-Lieu of Parking.....	9
G.	Electric Vehicle Readiness.....	9
<b>SECTION 8.0</b>	<b>PARKING LOT DESIGN STANDARDS</b> .....	<b>10</b>
A.	Location of Parking Areas.....	10
B.	Design of Parking Areas.....	10
C.	Internal Circulation of Parking Areas.....	10
D.	Size of Parking Stalls.....	10
E.	Design of Parking Stalls.....	11
F.	Paved Parking and Dimensional Standards.....	11
G.	Fire Lane Pavement Striping and Signage Standards.....	11
H.	EV Parking Space Design.....	12
I.	Accessibility of EV Spaces.....	12
J.	Parking Lot Design in Overlay Districts.....	13
<b>SECTION 9.0</b>	<b>HANDICAPPED ACCESS</b> .....	<b>14</b>
A.	Parking Spaces.....	14
B.	Passenger Loading Zones.....	15
<b>SECTION 10.0</b>	<b>REQUIRED OFF-STREET LOADING AND SERVICE AREAS</b> .....	<b>15</b>
A.	Required Area.....	15
B.	Arrangement.....	15
C.	Number of Spaces.....	15
D.	Building Alterations.....	16
<b>SECTION 11.0</b>	<b>RECREATIONAL VEHICLES AND ASSOCIATED EQUIPMENT STORAGE IN TOWNHOUSE AND MULTI-FAMILY RESIDENTIAL DEVELOPMENTS</b> .....	<b>16</b>
<b>SECTION 12.0</b>	<b>DRIVE-THROUGH LANES AND STACKING DISTANCES</b> .....	<b>16</b>
A.	Drive-through Requirements.....	16
B.	Stacking Distance.....	17
<b>SECTION 13.0</b>	<b>PARKING CALCULATIONS REQUIRED</b> .....	<b>17</b>
<b>FIGURE H-1</b>	.....	<b>18</b>
<b>FIGURE H-2 &amp; H-3</b>	.....	<b>19</b>
<b>FIGURE H-4</b>	.....	<b>20</b>
<b>FIGURE H-5</b>	.....	<b>21</b>

## **SCHEDULE H PARKING REQUIREMENTS**

### **SECTION 1.0      PURPOSE**

It is the purpose of this Schedule to establish standards which promote the orderly, efficient, and safe layout of parking and loading areas and to minimize the necessity for impermeable surface areas. Additionally, the City is encouraging implementation of higher-level design and promoting readiness for Electric Vehicles (EV) and resilient design.

### **SECTION 2.0      APPLICABILITY**

Off-street parking spaces shall be provided at the time of the development of any property, erection of any building or at the time any principal building is enlarged or increased in capacity by adding dwelling units, guest rooms, seats or floor area; or before the conversion from one (1) type of use or occupancy to another when the proposed use requires a greater number of parking spaces than the previous use,

Except as provided for under joint parking and shopping centers and malls, if a structure contains 2 or more types of use, each use shall be calculated separately for the purpose of determining the number of total off-street parking spaces required.

The total number of parking spaces required shall be rounded off to the closest whole number if the computations based on this Schedule result in any fractional requirement of a parking space. Fractional numbers ending in .5 shall be considered as the next whole space,

To promote resilience, applicants are encouraged to install EV charging spaces and infrastructure on development sites throughout the City. In certain instances, EV charging stations or infrastructure may be required at the discretion of the Administrative Official or designee or when the number of parking spaces exceeds predetermined thresholds.

### **SECTION 3.0      UNSPECIFIED USES**

The number of parking spaces for uses not specifically mentioned herein or unique cases shall be determined on an individual basis by the Administrative Official. Factors to be considered in such determination include, but are not limited to, size of building, type of use, number of employees, expected volume and turnover of customer traffic, expected frequency and number of delivery and service vehicles parking requirements for comparable uses specified in this Schedule and sound and generally accepted land use planning and engineering practices and principles.

### **SECTION 4.0      JOINT USE OF PARKING FACILITIES**

The City may authorize the joint use of parking facilities under the following conditions:

#### **A.      Shared Parking.**

Up to 50 percent of the parking facilities of a use considered to be primarily a daytime use or a weekday use may be used to satisfy the parking facilities required by this section for a use considered to be primarily a nighttime use or a weekend use.

#### **B.      Covenant Required.**

A binding covenant in a form approved by the City Attorney for any shared parking agreement shall be provided to the City and shall include such reasonable conditions as the City may impose.

## **SECTION 5.0            REDUCTIONS AND INCREASES IN REQUIRED NUMBER OF PARKING SPACES**

The Administrative Official may reduce the number of required off-street parking spaces when the applicant demonstrates in a parking study prepared by a traffic engineer or traffic planner good cause or when the Administrative Official finds that the applicant has demonstrated by competent and substantial evidence that a hardship exists regarding the development of the parcel. In such situations, the City may require land to be reserved for parking development should the use or needs change or require a fee in lieu payment or other mechanism consistent with [Section 7.0.F](#) of this schedule.

The Administrative Official may approve an increase or decrease in the number of parking spaces up to twenty-five percent (25 percent) of the number required when the applicant demonstrates in a parking study prepared by a traffic engineer or traffic planner good cause. The parking study must contain at least five examples of similar projects within 100 miles of the project location.

The Administrative Official shall have the discretion to require that an application for parking increase be heard by the Planning and Zoning Commission at a public hearing.

The Administrative Official may approve a reduction of parking spaces or parking stall size, if an applicant can demonstrate a higher level of design incorporating two of the following elements:

- A.     Additional usable open space above minimum required open space
- B.     Preservation of trees
- C.     Hardscaping elements
- D.     Enhanced landscaping
- E.     EV charging stations or installation of electric conduit to serve future EV infrastructure.
- F.     Fee in lieu payment

The Administrative Official shall have the discretion to require that an application for parking reduction be heard by the Planning and Zoning Commission at a public hearing.

The Planning and Zoning Commission may approve an increase or decrease in the number of parking spaces when the request exceeds 25% of the required when the applicant demonstrates in a parking study prepared by a traffic engineer or traffic planner good cause. The parking study must contain at least 5 examples of similar projects within 100 miles of the project location.

## **SECTION 6.0            BICYCLE PARKING REQUIRED**

### **A.     Purpose.**

The purpose of this Subsection is to provide adequate and safe facilities for the storage of bicycles.

### **B.     Applicability.**

Bicycle parking facilities shall be provided for any new building, addition or enlargement of an existing building, or for any change in the occupancy of a building that results in the need for additional auto parking facilities.

### **C.     Exemptions.**

No bicycle parking spaces shall be required for the following uses: single-family residence, two-family residence, funeral parlor, undertaker, cemetery, automobile repair or body shop, gas station and car wash.

#### **D. Bicycle Parking Spaces Required.**

Off-street bicycle parking shall be provided as follows:

1. For multi-family residences, there shall be one bicycle space or locker for every 5 dwelling units or portion thereof.
2. For all other uses, except exempted uses, one bicycle parking space shall be provided for every 20 parking spaces required pursuant to this Schedule.
3. In all cases where bicycle parking is required, a minimum of 2 and a maximum of 50 bicycle parking spaces shall be provided and distributed throughout the project.
4. The Administrative Official may reduce or eliminate the required number of bicycle parking spaces based on competent and substantial evidence provided by the applicant confirming that fewer bicycle parking spaces are required.
5. A maximum of 2 required vehicle parking spaces may be used for bicycle parking spaces.

#### **E. Location of Short-Term Bicycle Parking Facilities.**

##### **1. Visibility:**

Cyclists should easily spot short-term parking when they arrive from the street. A highly visible location discourages theft and vandalism. Locations "off on the side", "around the corner" or in un-supervised parking structures or garages shall be discouraged.

##### **2. Access:**

The parking area should be convenient to building entrances and street access, but away from normal pedestrian and auto traffic. Locations that require bicycles to travel over stairs shall be discouraged.

##### **3. Security:**

Surveillance is essential to reduce theft and vandalism. Parking shall be located within view of passers-by, retail activity, or office windows.

##### **4. Lighting:**

Bicycle parking areas should be well lit for theft protection, personal security and accident prevention.

##### **5. Weather Protection:**

Whenever possible, the bicycle parking area shall be protected from weather, using an existing overhang or covered walkway. Alternatively, a canopy or roof, either freestanding or attached to an existing building, shall be constructed.

##### **6. Avoid Conflict with Pedestrians:**

Racks shall be located to ensure that parked bicycles don't block the pedestrian path.

##### **7. Avoid Conflict with Automobile:**

Bicycle parking shall be separated from auto parking and road areas with space and a physical barrier to prevent motor vehicles from damaging parked bicycles.

#### **F. Design of Parking Facilities.**

1. The "Inverted U" type bike rack is the recommended bicycle parking rack for short-term parking. Any other type of proposed rack is subject to approval by the Administrative Official based upon demonstratable common practice. Any such alternate security device submitted for approval shall provide for:

- a. Supporting the bike frame at 2 locations (not just a wheel);
  - b. Allowing both the frame and at least 1 wheel to be locked to the rack (without requiring that the lock be placed near the bicycle chain);
  - c. Allowing the use of either a cable or “U-type” lock;
  - d. Bicycles which are equipped with water bottle cages;
  - e. Bicycles which are not equipped with kickstands; and
  - f. All types and sizes of bicycles, including various types and sizes of frames, wheel sizes, and tire widths.
2. All lockers and racks shall be securely anchored to the ground or the building structure to prevent the racks and lockers from being removed from the location.
  3. The surfacing of such facilities shall be designed and maintained to be mud and dust free. The use of rock or gravel areas for bicycle parking is permitted provided that edging materials, such as landscape timbers are used so that the bicycle parking area is clearly demarcated and the rock material is contained.
  4. Bicycle parking facilities shall be sufficiently separated from motor vehicle parking areas to protect parked bicycles from damage by motor vehicles. The separation may be accomplished through grade separation, distance or physical barrier, such as curbs, wheel stops, poles or other similar features.
  5. Required bicycle parking spaces shall be at least two 2’ by 6’ per bicycle.
  6. An aisle a minimum of 5’ wide shall be provided behind bicycle parking facilities to allow for maneuvering.
  7. Sufficient space, to be a minimum of 24”, shall be provided beside each parked bicycle to allow access. This access may be shared by adjacent bicycles. Racks shall be installed a minimum of twenty-four 24” from any wall or other obstruction.
  8. It is recommended that 1/2 of the bicycle parking spaces be provided as long-term parking, safe and secure from vandalism and theft, and protected from the elements. With the remainder being provided as short term (customer or visitor) parking, and it is recommended that these parking spaces be visible and convenient to the building entrance.
  9. Bicycle parking facilities shall be marked with a sign which includes a picture of a bicycle and the letter ‘P’ or the word ‘Parking’.

**G. Specifications for the "Inverted U" Type Bicycle Rack.**

(If proposed, all other racks must be approved by the Planning Director or designee).

The Inverted U’s shall be fabricated from 1½” Schedule 40 Pipe, in accordance with ASTM F 1083, 48.26 mm O.D. x 3.683 mm wall (1.90” x 0.145” wall). The U’s shall measure 914.4 mm high x 457.2 mm wide (36” high, 18” wide). The bicycle racks shall not be welded in sections. Only the base plate shall be welded to the steel pipe with 2 3mm (1/8”) vent holes - one on the inside of each upright where the pipe is welded to the baseplate. After fabrication, the rack shall be coated with a Thermoplastic (polyethylene copolymer based) powder coating (polymer) to a thickness 200-250 micrometers (8 - 12 mils). Racks installed Downtown must be “Federal Green”- Color #14056 as specified in the Federal Paint Specifications 595B. Racks shall be mounted to concrete via 190 mm (7 ½”) diameter baseplates 10mm (3/8”) thick steel in accordance with ASTM A 36, with 11 mm diameter (7/16”) mounting holes on each base plate, spaced equidistant between the upright pipe and edge of the baseplate. Expansion anchor shall be carbon steel mushroom head, 10 mm x 76 mm (3/8” x 3”) “spike” #5550 as manufactured by Rawl or approved equal

manufactured in the U.S. made from grade 8.2 materials exhibiting equivalent theft-proof performance. Racks shall be set firm and aligned with a tolerance of plus or minus ¼” from plumb. Where required, steel tapered shims shall be installed prior to anchoring in place. Any departure of base plate from grade by more than 3/8” shall require the separation to be filled with high-strength epoxy non-shrinking grout and made level.

**H. Long Term Bicycle Parking Facilities.**

Long term parking shall be provided for employees, bicycle commuters and tenants/owners in multifamily developments. Three common ways of providing secure long-term bicycle parking are: fully enclosed lockers accessible only by the user; a continuously monitored facility that provides at least medium-term type bicycle parking facilities; and restricted access facilities in which short term type bicycle racks are provided and access is restricted only to the owners of the bicycles stored therein. The easiest retrofit is the bicycle locker. Bicycle lockers are designed to be secure individual bikes with panniers, computers, lights, etc., left on the bike. Some designs of bike lockers can be stacked so there is twice the parking density. Good protection from the weather is another benefit. Bike lockers tend to be used most for long term bicycle commuter parking in areas without a lot of continuous oversight.

**SECTION 7.0 OFF-STREET PARKING REQUIREMENTS**

**A. Number of Automobile Parking Spaces.**

LAND USE CATEGORY		MINIMUM NUMBER OF PARKING SPACES REQUIRED PER INDICATED UNIT	UNIT OF MEASURE
<b>RESIDENTIAL</b>	One-Family Dwelling	2.0	Per dwelling unit.
	Mobile Home	2.0	Per dwelling unit.
	Multiple-Family Dwelling	2.0 <sup>2</sup>	Per dwelling unit.
	Townhouse	2.0 <sup>2</sup>	Per dwelling unit.
<b>MISCELLANEOUS</b>	Travel Trailer	1.0	Per travel trailer.
	Day Care Facility	4.0	Per 1,000 square feet Gross Floor Area (GFA) <sup>1</sup> .
	Residential Care Facility	1.0	Per 3 beds.
	Boarding House	1.0	Per sleeping room.
	PLUS	1.0	Per resident manager.
	Accessory Dwelling Unit; Accessory Residential Structure; Accessory Agricultural Housing	1.0	Per unit.
	<b>PUBLIC AND SEMI-PUBLIC</b>	Noncommercial Amusement Facility Indoor/Outdoor with fixed seating Without fixed seating	1.0 1.0
Educational Facilities Elementary School and Middle School		1.0	Per 9 students of maximum design capacity.

LAND USE CATEGORY		MINIMUM NUMBER OF PARKING SPACES REQUIRED PER INDICATED UNIT	UNIT OF MEASURE
<b>PUBLIC AND SEMI-PUBLIC</b>	High School, College, University or Vocational School	1.0	Per 4 students of maximum design capacity.
	Library	3.0	Per 1,000 square feet of GFA
	Cultural Facility Indoor	1.0	Per 1,000 square feet of GFA.
		Outdoor	1.0
	House of Worship	1.0	Per 3 seats based on maximum capacity of Auditorium or Principal Place of Assembly.
	Hospital	1.4	Per bed based on maximum patient capacity.
	Government Uses	1.0	Per parking space required based on non-government use of the same type.
<b>COMMERCIAL</b>	General Retail Sales and Service Indoor including commercial schools	5.0	Per 1,000 square feet of GFA.
	Convenience Store	7.0	Per 1,000 square feet of GFA.
	Retail, Large Goods	3.0	Per 1,000 square feet of GFA.
	Multi-tenant Shopping Center or Mall 100,000 square feet or less; Greater than 100,000 square feet	4.0	Per 1,000 square feet of GFA.
		3.0	Per 1,000 square feet of GFA.
	Outdoor Display-New Merchandise; New and Used Vehicular Dealers; Outdoor Display-Used Merchandise; Outdoor Storage	1.0	Per 1,000 square feet of Gross Sales and Storage Area (interior and exterior).
	Business and Professional Offices	4.0	Per 1,000 square feet of GFA.
	Medical and Dental Office	5.0	Per 1000 square feet of GFA.
	Restaurant	1.0	Per 3 seats based on maximum customer capacity.
	Fast Food Restaurant with Drive-through lane	1.0	Per 5 seats based on maximum customer capacity.
Self-Storage Facility	6.0	Adjacent to the office; and temporary loading zones must be provided on each side of the driving lanes that are adjacent to the storage buildings. Buildings must be 24' apart if 1 parking lane is provided and 32' apart if 2 parking lanes are provided.	

LAND USE CATEGORY		MINIMUM NUMBER OF PARKING SPACES REQUIRED PER INDICATED UNIT	UNIT OF MEASURE
<b>TRANSIENT LODGING AND ENTERTAINMENT</b>	Transient Lodging Establishment PLUS	1.0 .2	Per sleeping unit. Per restaurant seat or conference room based on maximum customer capacity.
	Commercial Amusements: Indoor/Outdoor With Fixed Seating	1.0	Per 4 seats based on maximum capacity.
	Without Fixed Seating	1.0	Per 200 square feet of floor and/or land area devoted to assembly or recreational use on the premises.
	Health Club	10.0	Per 1,000 square feet of GFA.
<b>AUTOMOTIVE</b>	Automobile and Truck Service; Automobile and Truck Repair; Automobile and Truck Rental; Automobile Rental Office; Major Equipment Rental; Major Equipment Repair; Automobile and Truck Accessory Sales and Installation	3.0	Per 1,000 square feet of GFA.
<b>MISCELLANEOUS BUSINESS &amp; SERVICES</b>	Funeral Home, Mortuary and/or Crematory	1.0	Per 4 seats based on maximum capacity of funeral service chamber or chapel.
	Laundry and Dry-Cleaning Plant	1.0	Per 1,000 square feet of GFA.
	Domestic and Business Service; Landscaping Service Establishment	3.0	Per 1,000 square feet of GFA.
	Auction Sales Establishment Inside	1.0	Per 4 seats based on maximum capacity of Place of Assembly.
	Outside	1.0	Per 50 square feet of area devoted to assembly on the premises.
	Veterinarian and Animal Hospital; Animal Boarding Kennel	3.0	Per 1,000 square feet of GFA.
<b>INDUSTRIAL</b>	Wholesale and Storage	1.0	Per 1,000 square feet of GFA.
	Manufacturing	2.0	Per 1,000 square feet of GFA.
	Junk Yard	1.0	Per acre of facility.
<b>AGRICULTURAL</b>	Agriculture Animal Raising	1.0	Per acre of facility.

Notes:

1. Gross Floor Area (GFA): The sum of the horizontal areas of the stories of a building or buildings, measured from the exterior faces of exterior walls or from the centerlines of walls which separate buildings. Included within such sum shall be the areas of all stories, including those areas which are not heated or air-conditioned, storage areas, interior balconies and mezzanines, and any other space reasonably usable for any purpose except parking.
2. The Administrative Official may reduce the required number of parking spaces based on competent evidence provided by a traffic engineer or traffic planner confirming that fewer vehicle parking spaces are required pursuant to [Section 5.0](#) of this schedule.



**B. Parking in the Special Commercial Zoning District (SC-3).**

**1. Existing Buildings, Existing Outdoor Seating Areas and Existing Sidewalk Cafes.**

- a. There shall be no off-street parking requirements for existing buildings in the SC-3 zoning district if there is no change in use or laps in occupancy in excess of 6 months.
- b. Existing buildings with outdoor seating on private property, may request vesting for existing outdoor seating within six (6) months of the adoption of this Section.
  - i. Any outdoor seating area that is not vested within six (6) months of adoption of this Section shall be deemed to have lapsed.
  - ii. Any outdoor seating area deemed to have lapsed, shall be considered non-conforming and subject to procedures of [Schedule L](#).
  - iii. Expansions to existing seating areas shall have parking calculated consistent with [Section 7.B.2](#).
- c. Existing approved sidewalk cafes are not eligible to vest however, an established sidewalk café is annually permitted to be renewed, subject to the provisions of [Schedule E](#).

Should an existing sidewalk café fail to annually renew, credit for up to eight (8) seats may be granted by the Administrative Official. Any additional seats will be assessed parking based on [Section 7.B.2](#).

**2. New Buildings, Outdoor Seating Areas or New Sidewalk café of Change of Use for Existing Buildings.**

- a. For change of use or expansion of an existing building, the Administrative Official may approve parking based on the pro rata share over and above the initial 5000 square feet. Any change to residential is required to meet the parking requirements.
- b. Outdoor seating area and event space shall be assessed parking based on the table below.
- c. The Administrative Official shall have the discretion to require that an application for parking reduction be heard by the Planning and Zoning Commission at a public hearing.
- d. New sidewalk cafes requesting to be permitted for more than 8 seats, shall be subject to the parking requirements in the matrix.
- e. Parking for all new buildings, outdoor seating area, and sidewalk cafes shall be approved by the Administrative Official using the parking matrix below:

Except that sidewalk cafes are subject to approval via procedures in [Schedule E](#):

LAND USE CATEGORY	MINIMUM NUMBER OF PARKING SPACES REQUIRED PER INDICATED UNIT <sup>1</sup>	UNIT OF MEASURE
RESIDENTIAL	1 0.5	Space for the initial unit (1 bedroom or studio). Space per additional bedroom.
RESTAURANT	1	Per 5 Seats.
TRANSIENT LODGING	1	Per sleeping room.
ASSEMBLY (NON-FIXED SEATING)	1	Per 200 square feet of assembly area.
ALL OTHER NON-RESIDENTIAL USES	1	Per 500 square feet.

Notes:  
**1.** The Administrative Official may reduce the required number of parking spaces based on competent and substantial evidence provided by a traffic engineer or traffic planner confirming that fewer vehicle parking spaces are required pursuant to [Section 5.0](#) of this schedule.

**C. Maximum Number of Parking Spaces.**

No development shall exceed the required number of parking spaces by more than twenty five percent (25 percent). However, the Administrative Official may approve parking increases up to 50 percent, when the applicant demonstrates good cause in a parking study prepared by a traffic engineer or traffic planner. At least five examples of similar projects within 100 miles of the project location must be included in the parking study. A percentage of any increase in parking spaces must include either EV charging stations or installation of electric conduit to serve future EV infrastructure.

**D. Parking of Company Vehicles.**

The minimum off-street parking space requirements for trucks and other similar company vehicles shall be 1 space for every vehicle operated by the establishment on the premises and for automobiles as shown in this Schedule, Minimum Automobile Off-Street Parking Space Requirements; provided however, that there shall be no off-street space requirements for existing buildings when such uses are located in an SC-3, Special Commercial Zoning District. The number of off-street parking spaces for company vehicles shall be evaluated and approved by the Administrative Official.

**E. Off-Street Parking Structures.**

All off-street parking structures designed to accommodate 5 or more vehicles shall comply with all area and dimension regulations for principal buildings as well as all off-street parking area buffer strip requirements included herein. All off-street parking structures designed to accommodate 4 or less vehicles, shall be considered as accessory buildings unless attached to a principal building. If attached to a principal building, such off street parking structures shall be subject to all the regulations of these Land Development Regulations for principal buildings and, if detached, such off-street parking structures shall be subject to all the regulations contained herein for accessory buildings.

**F. Fee In-Lieu of Parking.**

In the event that an applicant cannot provide required parking spaces onsite in the designated downtown parking district, the City shall establish a fee in lieu that may be paid for in its entirety or as a portion of the required parking subject to approval by the Administrative Official.

1. The applicant must submit a written request to the Administrative Official, requesting a fee in lieu agreement.
2. Such fee in lieu shall be set by resolution of the City Commission and amended from time to time.
  - a. The fee shall be based on a per parking space basis.
  - b. All fractions of a parking space shall be rounded as previously defined in this schedule and the full space fee in lieu be paid for each required parking space not provided.
  - c. The applicant may have the option to pay a fee in lieu for all or a portion of the required parking spaces.
  - d. In no instance may a fee in lieu be used to eliminate any required EV parking spaces.

**G. Electric Vehicle Readiness.**

The intention is to promote electric vehicle readiness and infrastructure in existing and new development within the City limits.

**1. Definitions.**

*EV Capable:* These parking spaces prepare for future Electric Vehicle Supply Equipment (EVSE) installation by providing dedicated electrical capacity in the service panel (40amp breaker for every two EV Capable two spaces) and conduit to the EV Capable space. These spaces do not require wiring to the space or a receptacle.

*EVSE Installed:* These parking spaces are reserved for EVs and provide drivers the opportunity to charge their electric vehicle using EV charging stations rated at a minimum of 32amp 7.2 kW. These spaces should be installed per the requirements of the National Electrical Code (NFPA 70) as adopted and amended by the State of Florida. This rates and wattage may be amended from time to time dependent on current standards.

**2. Number of Spaces Required.**

LAND USE TYPE	EV INSTALLED	EV CAPABLE
NON-RESIDENTIAL	2	20 percent
MULTIFAMILY	2	10 percent
INDUSTRIAL	1	5 percent

**SECTION 8.0 PARKING LOT DESIGN STANDARDS**

**A. Location of Parking Areas.**

Off-street parking area including required parking spaces, accessways, buffers and related off-street parking appurtenances, shall be provided for all buildings and uses on the premises; or, if approved by the City, such off-street parking may be located a maximum distance of 300’ from the premises it serves and/or may be consolidated into a large parking area serving other buildings and uses provided that such off-street parking space shall be maintained, regulated and enforced as if it were actually located on the premises it is designed to serve.

The applicant must provide a binding plan, deed or other proof necessary to show that the required parking space, if approved to be located off the premises it serves, is controlled by and available to, the applicant for as long as the use it is intended to serve is in existence.

**B. Design of Parking Areas.**

All parking area designs shall comply with Figure H-1 of this Schedule.

**C. Internal Circulation of Parking Areas.**

1. The internal design of the parking area shall be designed to facilitate vehicular circulation and avoid conflict between pedestrian and vehicular movements. Internal circulation also shall be designed so as not to create conflict with access into or egress from the site and shall be consistent with the landscape requirements of these land development regulations.
2. Each parking stall shall be accessible from an aisle or driveway and designed so that no automobile shall back into a public street in order to exit a parking stall.
3. Parking Aisle Width. Minimum access way shall be 12’ for one-way traffic and 24’ for two-way traffic.

**D. Size of Parking Stalls.**

The minimum size of parking spaces shall be as follows:

<b>REGULAR (NON-HANDICAPPED)<sup>1,2</sup>:</b>	10’ wide	20’ long
<b>PARALLEL:</b>	9’ wide	20’ long
<b>ADA SPACE (PLUS 5’ LANDING):</b>	12’ wide	20’ long

Notes:

1. The Administrative Official may reduce the required parking stall size based on competent evidence provided by an applicant demonstrating a higher level of design by incorporating EV parking spaces, installation of electric conduit to serve future EV infrastructure, or other site enhancements approved by the Administrative Official.
2. Except in the SC-3 Zoning District, which shall be permitted with a minimum of 9’ wide by 18’ long for regular parking, 9’ wide by 23’ long for parallel parking and the minimum required by Federal Standards for any required ADA spaces.

**E. Design of Parking Stalls.**

All paved parking stalls shall have 4” white lines between spaces to indicate individual stalls, and each stall may be required to be equipped with wheel stops if deemed appropriate by the City based upon competent evidence.

Wheel stops for stalls adjacent to landscaped strips shall be located 2½’ from the front end of the stall to prevent encroachment into required landscaped areas. The front two 2’ of the stall may be kept as a maintained vegetative ground cover area although no credit will be extended toward the open space requirements of these regulations.

**F. Paved Parking and Dimensional Standards.**

All required parking spaces and vehicular use areas shall be paved.

1. Asphaltic paving shall provide a 1” thick asphalt surface, a 4” thick base and a 6” thick subgrade.
2. Concrete paving shall provide a 5” thick Portland concrete surface with a compressive strength of 3,000 p.s.i. and a subgrade with a Fla. Bearing Value of 75 p.s.i.
3. Such paved areas shall be provided with positive drainage and shall not permit ponding depth of greater than 1/8”.
4. Curbing or bumper stops shall be provided to protect all required landscaped areas and buildings.
5. All parking spaces shall be striped white. Such striping shall be a minimum of 4” wide and shall conform to the FDOT's Standard Specifications for Road and Bridge Construction, latest edition. All striping and other traffic control devices shall conform and be maintained to the latest edition of the Manual on Uniform Traffic Control Devices. Painted wooden regulatory signs shall not be deemed to comply with these regulations. All driveways exiting on to any public or private street shall be controlled by a High Intensity 30” stop sign. 24” stop signs shall be used internally. The clearance from the finished ground elevation to the bottom of all signs shall be at least 7”. All handicap parking spaces shall be in accordance with the requirements of Florida Law.
6. Required parking spaces and vehicular use areas for residential uses with less than 10 required parking spaces may utilize a substitute surface for such off-street parking and vehicular use areas. Such surface shall be specified in terms of thickness and other relevant characteristics, must be maintained continuously in an approved condition and approved by the Administrative Official. If the substitute surface is not maintained properly, the Administrative Official shall have the authority to take actions necessary to ensure that the area in question is paved in a manner that conforms to the requirements of this Schedule and that all actions to that end shall be at the sole expense of the owner. Small-scale nonresidential uses may request from the Administrative Official to utilize a substitute surface for off-street parking and vehicular use areas in accordance with these Land Development Regulations.

**G. Fire Lane Pavement Striping and Signage Standards.**

Buildings and sites which are required to include fire lanes shall comply with the following standards.

**1. Pavement Striping.**

Fire lane pavement striping shall be yellow and painted of thermoplastic or an equivalent substitute. The perimeter of the striping shall begin at the curb and extend to a width of 8’ parallel to the curb. The perimeter lines and required striping within the perimeter shall be 4” wide with a 10” space between stripes. The stripes shall not be painted over or under the painted words required below.

## **2. Painted Letters on Pavement.**

The words "NO PARKING FIRE LANE" shall be painted within the perimeter of the fire lane striping. The stroke of each letter shall be 4" wide and shall be painted in yellow FDOT traffic-rated reflective paint. Each repeated phrase shall be painted not more than 100' apart.

## **3. Signs.**

Fire lane signs shall be installed not more than 100' apart and shall contain the words "NO PARKING FIRE LANE". The background and lettering of signs shall have a high intensity reflective facing.

## **4. Relationship of Pavement Lettering and Sign Locations.**

Pavement lettering and signs shall be staggered in location so that each are not more than 50' apart.

## **5. Curb Painting.**

All curb facing shall be painted yellow for the entire length of the fire lane using a FDOT traffic-rated reflective paint.

## **H. EV Parking Space Design.**

1. EV installed charging stations incorporated into sites count toward the minimum required parking spaces.
2. Charging equipment must be mounted on the wall or on a structure at the end of the electric vehicle parking space provided.
3. No charging devices may be placed within the dimensions of a space, on the sides, or entrance to a space.
4. EV spaces shall be in close proximity to the building served by the associated off-street parking area.
5. Multifamily developments must provide 50 percent of EV installed parking spaces or E capable spaces adjacent to each multifamily building.
6. When cords and connectors are not in use, retraction devices or locations for storage shall be located sufficiently above the pedestrian surface and the parking lot as to reduce conflicts with pedestrians and vehicle maneuvering.
7. Cords, cables, and connector equipment shall not extend across the path of travel in any sidewalk or walkway.
8. Equipment mounted on structures such as pedestals, lighting posts, bollards, or other device shall be located in a manner that does not impede pedestrian, bicycle, or transit travel.
9. The design of the EV installed space shall comply with [Figure H-5](#) of this Schedule. Alternative designs may be approved by the Administrative Official or designee.
10. Additional landscape screening may be required for mechanical equipment such as transformers associated with charging equipment at the discretion of the Administrative Official.

## **I. Accessibility of EV Spaces.**

1. When EV spaces are installed at least one space must be accessible from an ADA designated parking space.
2. All charging equipment shall be in accessible reach and in a barrier free aisle for the user to move freely between the equipment and the vehicle.

3. Charging equipment may not be located in any required access aisle.

## **J. Parking Lot Design in Overlay Districts.**

Overlay Districts as defined in [Schedule U](#), have variable parking lot design standards and shall comply with the following standards:

### **1. Lake Mary Boulevard and West SR 46/Rinehart Road Overlay:**

- a. Parking bays shall not be larger than forty (40) spaces.
- b. Parking lot lighting shall be designed as follows: Illumination onto adjacent properties shall not exceed 0.5 foot-candles. Cut-off fixtures are required to conceal the actual source of the light which reduces glare and to direct the light to specific areas while shielding other areas. The maximum height of the light pole shall be 25', including the base. The minimum setback of the light source from the property line shall be a horizontal distance of 20'.

### **2. Downtown/Riverfront/Midtown Overlay District.**

(refer to [Schedule U](#) for street and block typologies).

- a. Off-street parking (surface parking lots).
  - i. A knee wall shall be constructed for the length of any parking lot which fronts a "Pedestrian Priority" or an "A" street. The knee wall shall be constructed using the following standards:
    1. Minimum 2'in height to a maximum of three 3'.
    2. The knee wall must be masonry or brick which complements the primary building's architecture by utilizing the same architectural style.
  - ii. A maximum of two (2) vehicular access/curb cuts to parking lots are allowed along "A" Street block faces, subject to Access Management regulations of [Schedule N](#). Vehicular access/curb cuts are not allowed on any block face less than 350'. Vehicular access drives shall connect each parking lot with at least two (2) separate streets.
- b. Parking Garages.

Structured parking decks shall be located behind "A" Street frontage buildings with vehicular access restricted to "B" Streets. Interior landscaping requirements for parking garages shall be met by providing hanging baskets, landscape planters and/or flower boxes around the exterior of the first three (3) levels of the parking garage structure. Parking structures that permit access from an "A" or "Pedestrian Priority" Street shall comply with the following requirements:

  - i. Direct pedestrian access to each adjacent street shall be provided.
  - ii. Except for vehicle entrances as described below, the ground floor shall be developed with enclosed commercial or civic floor space to a minimum building depth of 30' along the entire length of the structure on each facing street, unless separated from the street by another building, parking lot and/or landscaped open space with a minimum depth of 30'.
  - iii. Vehicle entrances to a parking structure shall be a maximum of 40' in width and shall be separated from other vehicle entrances to the structure or other parking structures on the same side of the block by a minimum distance of 400'.
- c. Parking within the SC-3 zoning district in any of the designated overlay districts shall comply with the parking standards established herein.
- d. Parking in any Overlay District not within the SC-3 zoning district shall comply with the parking as determined for that use and as established herein.
- e. Parking lots shall be designed to allow pedestrians to safely move from vehicles to the building.
- f. Parking Lots containing more than thirty-six (36) parking stalls shall have clearly defined pedestrian connections provided between:

- i. A public right-of-way and building entrances
  - ii. Parking lots and building entrances
- g. Residential Development.
- i. Street-facing ground floor parking, including garages, is not permitted on the first (1) floor of a multifamily structure on an “A” street or a “Pedestrian Priority” street. Parking shall occur underneath the multifamily structure, within parking garages, or within surface lots that do not front on either an “A” Street or a “Pedestrian Priority” Street.
  - ii. Front garages must be set back a minimum of 5’ from the primary structure.
  - iii. Rear garages must be set back a minimum of 4’ from an alley or rear access drive. On corner lots on ‘A’ or ‘Pedestrian Priority’ streets with alley access, garage doors shall not face side streets.
  - iv. Side garages may have an access from the street and are required, at a minimum, to be set back in line with the primary structures side setback.
  - v. Ground floor parking, including garages that are located inside the internal block are permitted on the first floor of a structure if the street facing side view of the garage blends in with the design elements of the building’s primary frontage.

## **SECTION 9.0      HANDICAPPED ACCESS.**

Parking spaces designated for physically handicapped people and accessible passenger loading zones that serve a particular building shall be located on the shortest possible circulation route to an accessible entrance of the building. In separate parking structures or lots that do not serve a particular building, parking spaces for physically handicapped people shall be located on the shortest possible circulation route to an accessible pedestrian entrance of the parking facility.

### **A.      Parking Spaces.**

1. Any commercial real estate property owner offering parking for the general public shall provide specially designed and marked motor vehicle parking spaces for the exclusive use of physically disabled persons who have been issued parking permits pursuant to Florida Law.
2. Diagonal or perpendicular parking spaces shall be a minimum of 12’ wide, as illustrated in [Figure H-2](#), Handicap Sign and Parking Space Standards.
3. Parallel parking spaces shall be located either at the beginning or end of a block or adjacent to alley entrances as illustrated in [Figure H-3](#), Passenger Loading Zones.
4. Each such parking space shall be conspicuously outlined in blue paint, and shall be posted and maintained with a permanent, above-grade sign bearing the international symbol of accessibility or the caption "PARKING BY DISABLED PERMIT ONLY," or bearing both such symbol and caption as illustrated in [Figure H-2](#), Handicap Sign and Parking Space Standards. Such signs shall not be obscured by a vehicle parked in the space. All handicapped parking spaces must be signed and marked in accordance with the standards adopted by the FDOT.
5. All spaces shall have an adjacent access aisle 60” wide minimum, as illustrated in [Figure H-2](#), Handicap Sign and Parking Space Standards. Parking access aisles shall be part of the accessible route to the building or facility entrance and shall comply with the requirements of Florida Law. 2 accessible parking spaces may share a common access aisle. Parked vehicle overhangs shall not reduce the clear width of an accessible circulation route.
6. All spaces shall have access to a curb-ramp or curb-cut, when necessary to allow access to the building served, and shall be located so that users will not be compelled to wheel behind parked vehicles.

7. The minimum number of such parking spaces shall comply with the following table:

TOTAL NUMBER OF PARKING SPACES IN LOT	REQUIRED NUMBER OF ACCESSIBLE SPACES
Up to 25	1
26 to 50	2
51 to 75	3
76 to 100	4
101 to 150	5
151 to 200	6
201 to 300	7
301 to 400	8
401 to 500	9
501 to 1000	2% of Total
Over 1000	20 plus 1 for each 100 over 1000

**B. Passenger Loading Zones.**

Passenger loading zones shall provide an access aisle at least 48” wide and 20’ long adjacent and parallel to the vehicle pull-up space as illustrated in [Figure H-3](#) & [H-4](#), Passenger Loading Zones. If there are curbs between the access aisle and the vehicle pull-up space, then a curb ramp complying with the requirements of Florida Law.

A minimum vertical clearance of 108” shall be provided at accessible passenger loading zones and along vehicle access routes to such areas from site entrances.

**SECTION 10.0 REQUIRED OFF-STREET LOADING AND SERVICE AREAS.**

**A. Required Area.**

Off-street loading and service area space shall be provided on the premises of all public and semipublic, commercial, transient lodging and entertainment, automotive, miscellaneous business and services, industrial and agricultural processing establishment uses so that no loading, unloading or servicing of buildings by refuse collection, fuel or other public or private service type vehicular activity will be generated on any required off-street parking space or on any street. Each required off-street loading, unloading and service area space shall be at least 60’ in depth, unless competent evidence is provided to the Administrative Official to include a certification by a licensed Florida professional engineer, 12’ in width, with an overhead clearance of not less than sixteen 16’ for each such space required; or, if approved by the Administrative Official, a total area at finished grade of at least 720 square feet devoted to such use with an overhead clearance of not less than 14’ for each such space required regardless of actual space dimensions and design.

**B. Arrangement.**

The off-street loading, unloading and service area space shall be arranged so that it may be used without blockage or interference with the use of adjacent streets, accessways or off-street vehicular or pedestrian traffic circulation.

**C. Number of Spaces.**

The Administrative Official shall interpret and approve the amount of loading, unloading and service area space required for all public and semi-public, commercial, transient lodging and entertainment, automotive, miscellaneous business and services, industrial and agricultural processing establishment uses based on the following total gross floor area of each building located on the premises:



GROSS FLOOR AREA (SQUARE FEET)	NUMBER OF LOADING SPACES
5,000-25,000	One (1) Space
25,001-60,000	Two (2) Spaces
60,001-120,000	Three (3) Spaces
Each additional 100,000 square feet, or major fractional thereof	One (1) Additional Space

**D. Building Alterations.**

The Administrative Official shall determine the amount of off-street loading, unloading, and service area for commercial uses based on a building's gross usable floor area and not the net usable floor area so as to accommodate any future alterations in the use of interior space.

**SECTION 11.0 RECREATIONAL VEHICLES AND ASSOCIATED EQUIPMENT STORAGE IN TOWNHOUSE AND MULTI-FAMILY RESIDENTIAL DEVELOPMENTS.**

In the case of multi-family and townhome residential developments the storage of recreational and other such equipment shall be regulated as follows:

- A. All multi-family and townhome developments with more than 25 dwelling units shall provide a designated area for the parking and storage of recreational vehicles, boats and equipment.
- B. The designated area shall be at a distance as remote as practical and in accordance with sound and generally accepted design and land use practices and principles from the dwelling units. The parking area for boats, trailers, jet skis and similar types of equipment shall be screened with plant material, decorative walls, fences, berms or any combination thereof, in an effort to diminish any visual impact that the area may have on the rest of the site. Parking for recreational vehicles need not be screened.
- C. The designated area shall be a paved surface consistent with the rest of the parking area within the development and shall provide ample ingress and egress and space for easy maneuverability for the type of vehicles and equipment using the area.

**SECTION 12.0 DRIVE-THROUGH LANES AND STACKING DISTANCES**

**A. Drive-through Requirements.**

Drive-through lanes and windows shall be designed to the following standards:

- 1. Drive through windows and lanes shall not be located on a side of the building fronting a street.
- 2. Hedges. A dense hedge of evergreen shrubs shall be provided in the following manner:
  - a. At initial planting and installation, shrubs shall be at least 30” in height and shall be planted thirty 30” or less on center.
  - b. Within 1 year of initial planting and installation, shrubs shall have attained, and be maintained at, a minimum height of 4’ and shall provide an opaque vegetative screen between the street and the drive-through. The hedge must continue for the entire length of the drive-through cueing or stacking area.
  - c. In lieu of a vegetative hedge, the use of vegetated berms with appropriate landscape materials may be used in a manner that results in the visual separation of street right-of-way and the drive-through.

**B. Stacking Distance.**

The following minimum stacking distances, measured from the point of entry to the center of the farthest service window area, are required:

Restaurants, full service car washes, day care facilities:	220'
Banks (per lane):	176'
Self Service Car Wash (per bay) and Dry Cleaners:	66'

Facilities not listed above with more than one drive-through lane shall provide 100' of stacking distance per lane measured from the point of entry to the center of the farthest service window area. In all other cases, the Administrative Official shall have the authority to determine the stacking distance for other uses on a case-by-case distance based upon the application of sound engineering practices and principles.

The drive-through lane shall be a separate lane from the circulation routes and aisles necessary for ingress and egress from the property or access to any off-street parking spaces.

For lanes greater than 175' a pass-through lane shall be constructed adjacent to at least 1 stacking lane in order to provide a way out of the stacking lane.

**SECTION 13.0 PARKING CALCULATIONS REQUIRED.**

All applications for development approval shall include parking calculations indicating the required number of parking spaces pursuant to this Schedule Parking calculations shall be included on required plans in a site development table.

**FIGURE H-1**

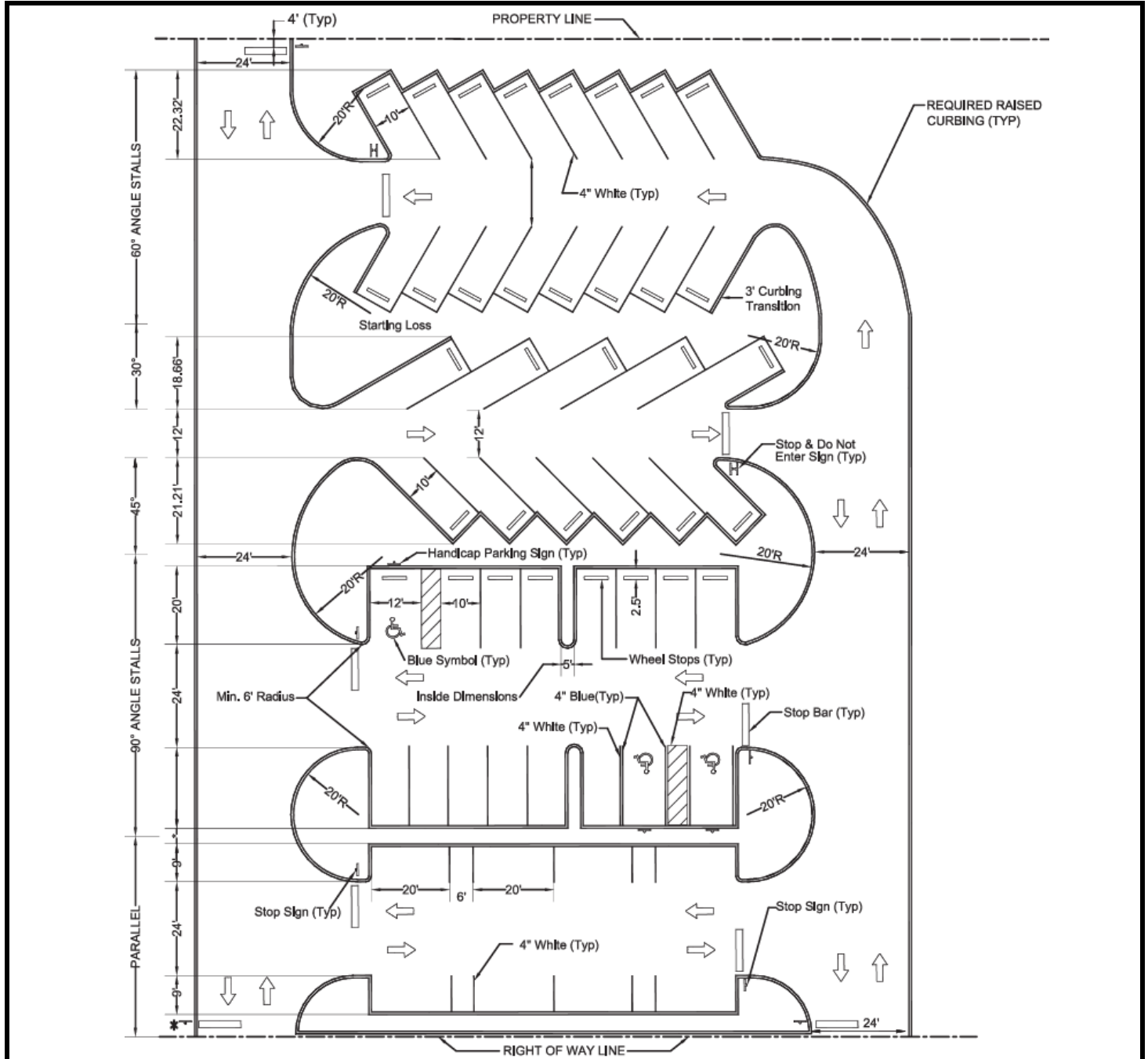

PARKING ANGLE	CURB LENGTH	STALL DEPTH	STARTING LOSS	LAST CAR REQUIREMENTS	AISLE WIDTH	
					12'	24'
30°	20'	18.66'	32.32'	5.00'	12'	24'
45°	14.14'	21.21'	21.21'	7.07'	12'	24'
60°	11.55'	22.32'	12.88'	8.66'	17'	24'
90°	10'	20'	5' MIN	10.00'	24'	24'

ONE WAY : TWO WAY

**NOTES:**

1. Minimum requirements shown.
2. All signage shall comply with the Manual on Uniform Traffic Devices.



**PARKING STANDARDS**

Date: August 2004

Drawn By: M. Jones

**FIGURE H-1**

FIGURE H-2 & H-3

FIGURE H-2  
HANDICAP SIGN AND PARKING SPACE STANDARDS

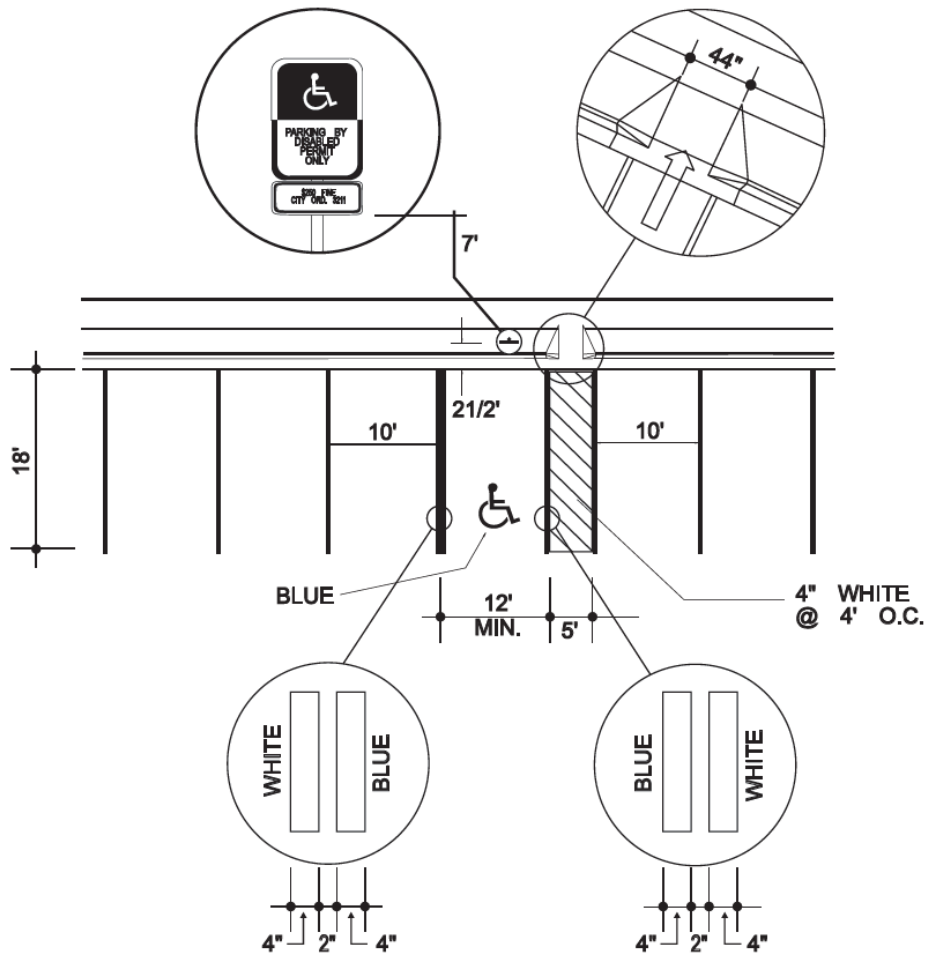
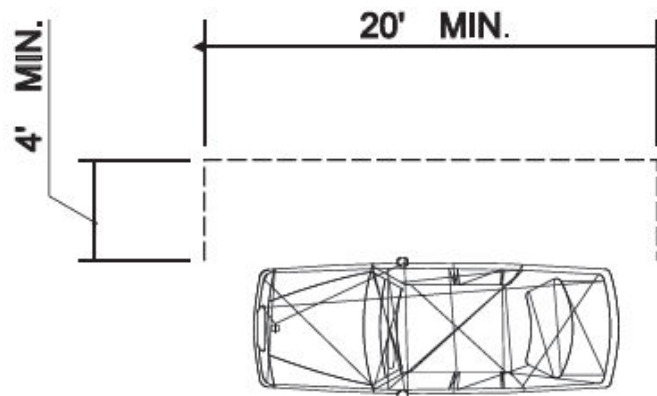

FIGURE H-3  
PASSENGER LOADING ZONES



CITY OF  
**SANFORD**  
DEVELOPMENT SERVICES

**HANDICAP SIGN/PARKING AND  
PASSENGER LOADING ZONES**

Date: August 2004

Drawn By: M. Jones

**FIGURE  
H-2  
&  
H-3**

**FIGURE H-4**

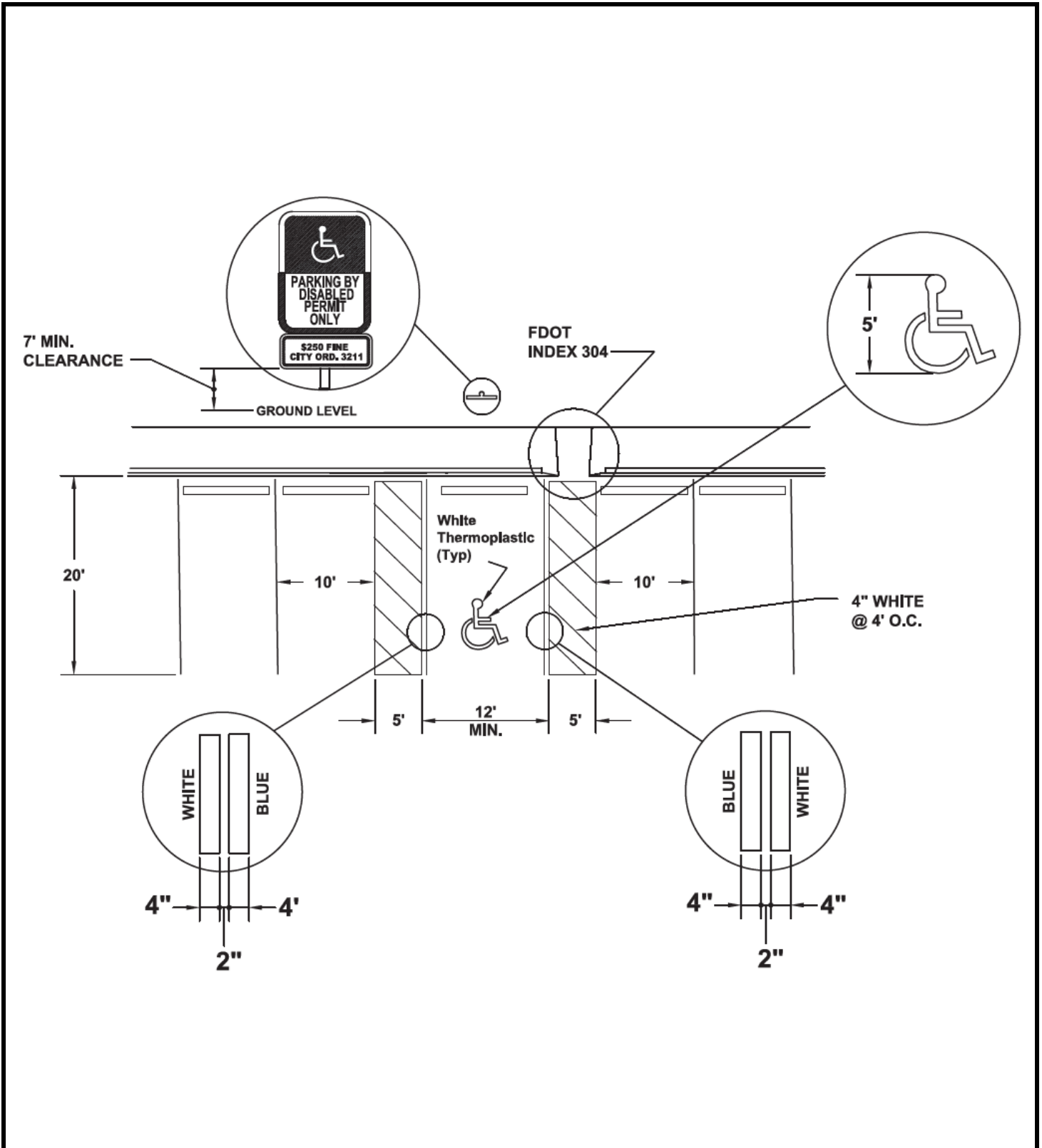

CITY OF  
**SANFORD**  
DEVELOPMENT SERVICES

**ALTERNATIVE LOADING FOR  
ACCESSIBLE PARKING**

Date: May 2023

Drawn By: M. Jones

**FIGURE  
H-4**

**FIGURE H-5**

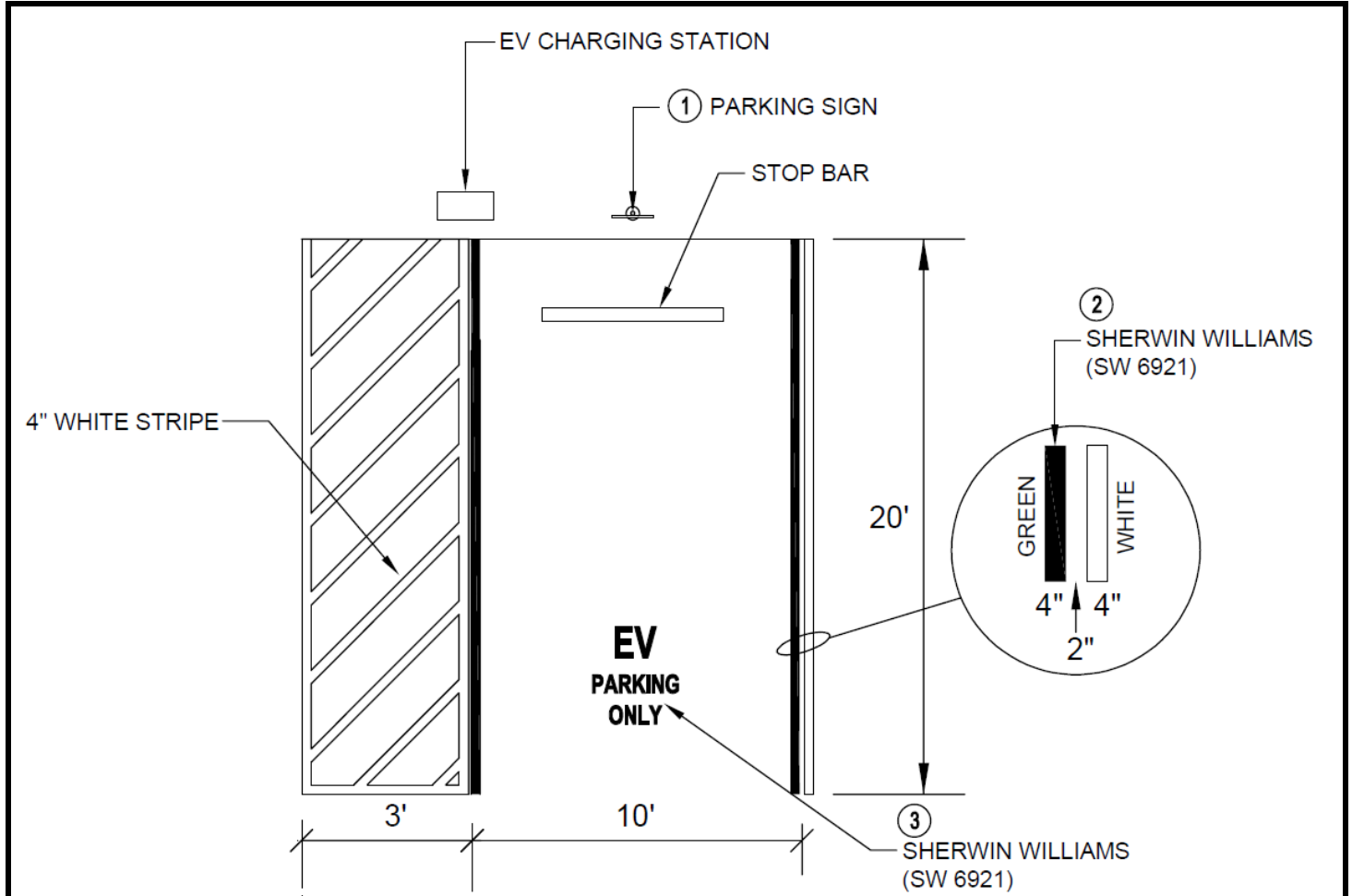

- ① **PARKING SIGN DESIGN:**
  - SIGN TEXT SHALL READ: “ELECTRIC VEHICLE PARKING ONLY” OR “ELECTRIC VEHICLE CHARGING ONLY”.
  - SIGN DIMENSIONS: 18.2 INCHES HIGH BY 12.2 INCHES WIDE.
  - SIGN COLOR: GREEN BORDER ON SIGNAGE TO MATCH WITH GREEN STRIPING ON PARKING SPOT.
  - SIGN HEIGHT: 72 INCHES FROM THE BOTTOM OF THE SIGN TO THE GROUND.
- ② **PARKING SPOT STRIPING:**
  - STRIP COLOR: ELECTRIC LIME GREEN - SHERWIN WILLIAMS (SW 6921).
  - STRIP LOCATION: PAINT A GREEN STRIP ON THE ‘INSIDE’ OF THE WHITE PARKING BOARDER.
- ③ **PARKING SPOT STENCIL:**
  - STENCIL TEXT SHALL READ: “ELECTRIC VEHICLE PARKING ONLY” OR “EV PARKING ONLY”.
  - STENCIL DIMENSIONS: 12 INCHES HIGH BY 66 INCHES WIDE, 1/16” THICK.
  - STENCIL COLOR: WHITE.



**ELECTRIC VEHICLE CHARGING STATION DETAIL**

**FIGURE H-5**

Date: June 2023

Drawn By: D. Tucker